



Nikko-Rack

QUICK ADJUSTABLE MAGAZINES PAT.

NIX,INC.

Super Nikko-Rack SIZE-M Assembly Manual

Article
R25, N25, SR25

Read this manual carefully before assembly.

Operating precautions

- Do not use under any circumstances such as detergent, nut and bolt locker, grease, or other organic solvent. This might result in deformation or damage.
- Do not use this product as a stool to stand or sit on. Any such practice might damage the product, resulting in injury.
- Do not throw this products or apply a strong impact to it. This might result in deformation or damage.
- Do not expose this product to direct sunlight or ultraviolet radiation. Any such practice may result in deformation or damage.
- Before moving this product, be sure to check that the lever is locked. The moving parts may move when you least expect it, resulting perhaps in getting your finger or other part of your body caught.
- Do not put this product into a hot drying furnace. Any such practice might result in deformation or damage.
- When reassembling or otherwise handling this product, be careful about the sharp tips of the parts. They may result in injury.

List of parts

①-A Guide rail unit A ...1unit



①-B Guide rail unit B ...1unit

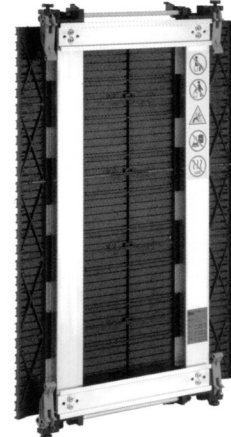

② Base 2pcs

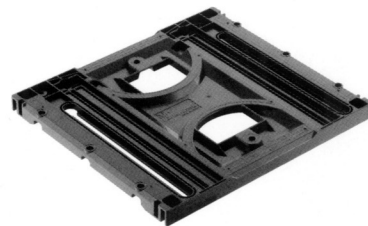

*The two base(top and bottom plates) are identical.

③ Guide channel U 2pcs



④ Hexagon socket head cap screw M6×16 8pcs



⑤ Flat washer ... 8pcs

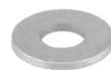

Composition of parts.

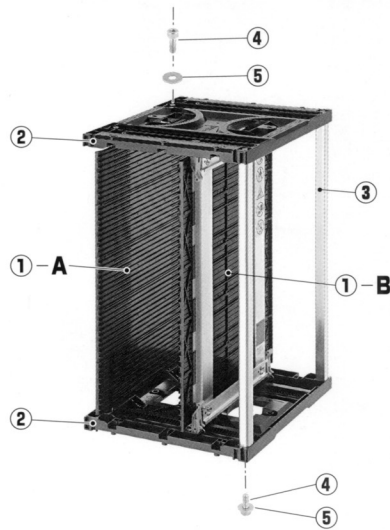

Assembly procedure *Assemble the parts in numerical order : ① to ④.

① Installing guide channel U.

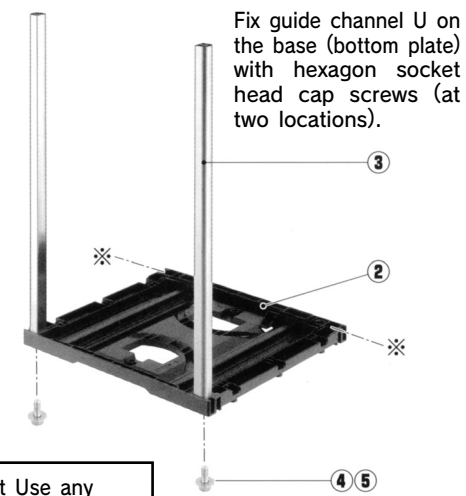

Do Not Use any chemical or Grease such as NUT and BOLT LOCKER

② Installing guide rail unit A

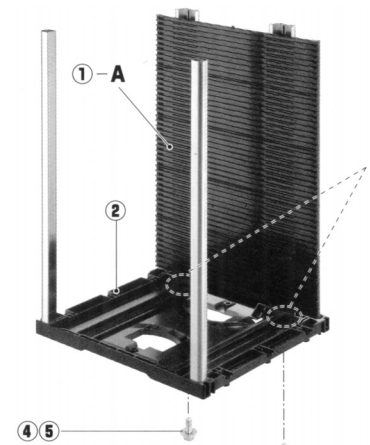

Do Not Use any chemical or Grease such as NUT and BOLT LOCKER

③ Installing guide rail unit B

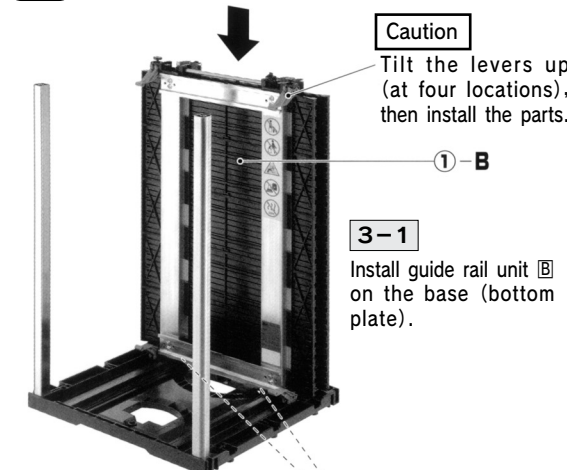

Caution Tilt the levers (at four locations), then install the parts.

3-1 Install guide rail unit B on the base (bottom plate).

At that time, fit the lug at the bottom of Unit B into the groove in the base (see the right-hand side of the photo).

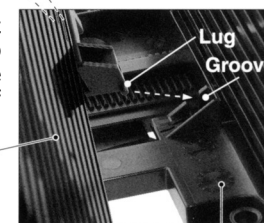

Guide rail unit B

Base (bottom plate)

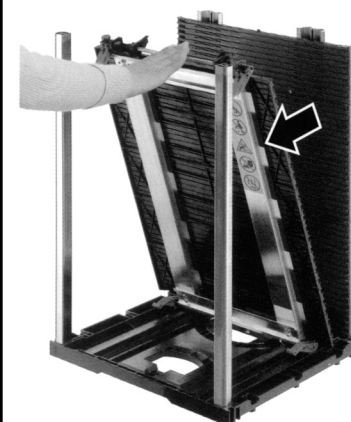

3-2 Next, tilt guide rail unit B towards you as shown in the photo.

④ Installing the base (top plate)

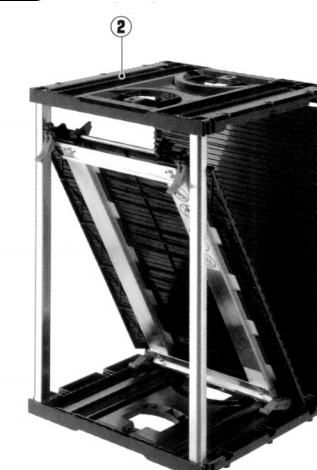

4-1 install the base (top plate). In that stage, do not fix it with hexagon socket head cap screws.

4-2 Then hold the part of the base (top plate) closest to you with your left hand, while press the top of guide rail unit B towards Unit A with your right hand until it clicks (see the bottom portion of the photo).

4-3 Press the floating base (top plate) from above, thus making it so that the pin of Unit B becomes visible.

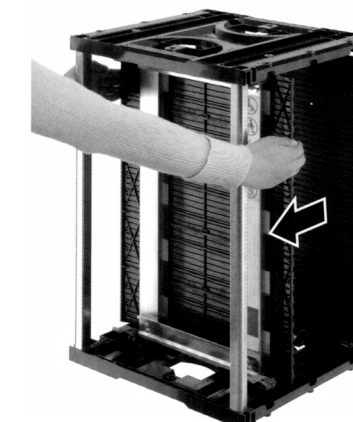
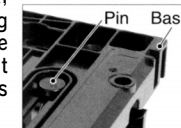

4-4 Slide guide rail unit B towards you, then fix the base (top plate) with hexagon socket head cap screws (four locations).

Assembly complete

Tightening tool: Hex wrench (2-sided width: 5 mm), tightening torque: 2.70 ± 0.25 N · m (2.45-2.95 N · m)

This product is compliant with the RoHS Directive.